

Model VCD-43

Extruded Airfoil Blade Control Damper

Low Leakage

Aluminum Frame Construction

Application and Design

The VCD-43 is a low leakage damper with extruded aluminum airfoil blades and frame. Smooth profile extruded aluminum airfoil blades insure the lowest resistance to airflow in HVAC systems. This model is intended for application in medium to high pressure and velocity systems.

VCD-43 is IECC (International Energy Conservation Code) compliant with a leakage rating of 3 cfm/ft² at 1 in. wg (55 cmh/m² at .25 kPa) or less.

Damper Ratings (See page 4 for specific limitations)

- Pressure:** Up to 8 in. wg (2 kPa) - pressure differential
For pressures greater than 8 in wg, consult factory.
- Velocity:** Up to 6000 fpm (30.5 m/s)
- Leakage:** Class 1A at 1 in. wg (0.25 kPa)
Class 1 at 4 - 8 in. wg (1 kPa - 2 kPa)
- Temperature:** -40°F to 250°F (-40°C to 121°C)



*W&H dimension furnished approximately 1/4 in. (6mm) undersize.

Construction	Standard	Optional
Frame Material	Aluminum (6063T5)	-
Frame Material Thickness	0.125 in. (3.2mm)	-
Frame Type	5 in. x 1 in. (127mm x 25mm) hat channel	Single Flange, Reverse Flange or Quick Connect
Blade Material	Extruded Aluminum (6063T5)	-
Blade Type	Airfoil	-
Blade Action	Opposed	Parallel
Linkage	Plated steel out of airstream, concealed in jamb	316SS
Axle Bearings	Synthetic (acetal) sleeve	316SS
Axle Material	Plated steel	316SS
Blade Seals	TPE	Silicone
Jamb Seals	Stainless Steel	-
Finish	Mill finish	Baked Enamel, Hi Pro Polyester, Industrial Epoxy, Kynar/Hylar (70%), Anodize

Size Limitations

in. (mm) W x H		Frame Type		
		Channel	Quick Connect	Single or Reverse Flange
Minimum Sizes*		8 x 6 (203 x 178)	8 x 5 (203 x 127)	8 x 6 (203 x 178)
Maximum Sizes	Single Section	60 x 74 (1524 x 1880)		
	Multiple Section	288 x 222 (7315 x 5639)	144 x 148 (3658 x 3759)	288 x 222 (7315 x 5639)

* varies by actuator

Blade Operation

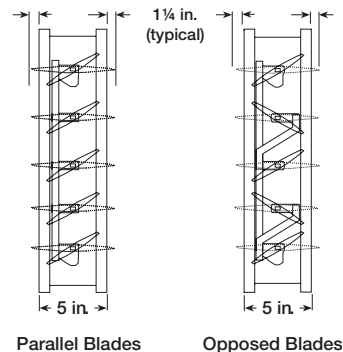

Notes:

- Low profile head and sill are used on sizes less than 17 in. high (432mm), excluding quick connect frame.
- Airfoil (streamlined) blade shape for reduced turbulence and lower pressure drop at velocities to 6000 fpm (30.5 m/s).
- Blades must be horizontal for either horizontal or vertical mount.
- If you need vertical blades, see VCD-43V model.
- Electric actuators and manual operators available. Factory supplied actuators are sized for 1500 fpm (7 m/s) and fully-closed differential pressure of 2 in. wg (.5 kPa). Contact factory for actuator sizing on applications exceeding those limits.

Frame Type Options

VCD-43

Channel Frame

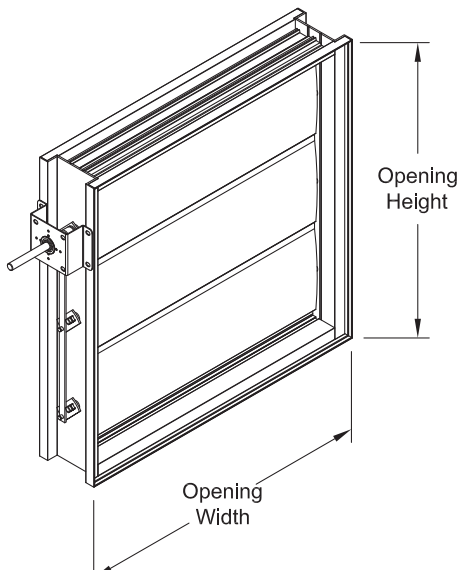

Single Flange

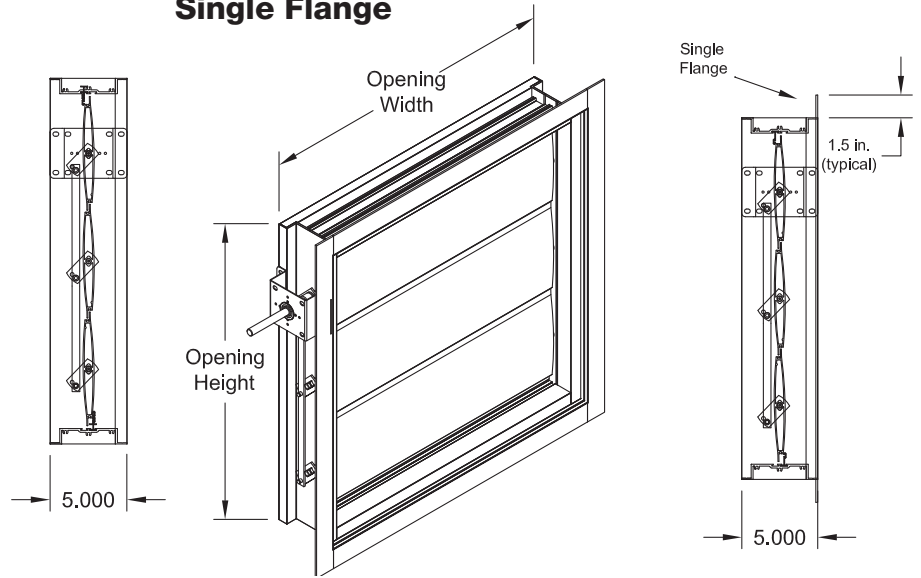

Reverse Flange

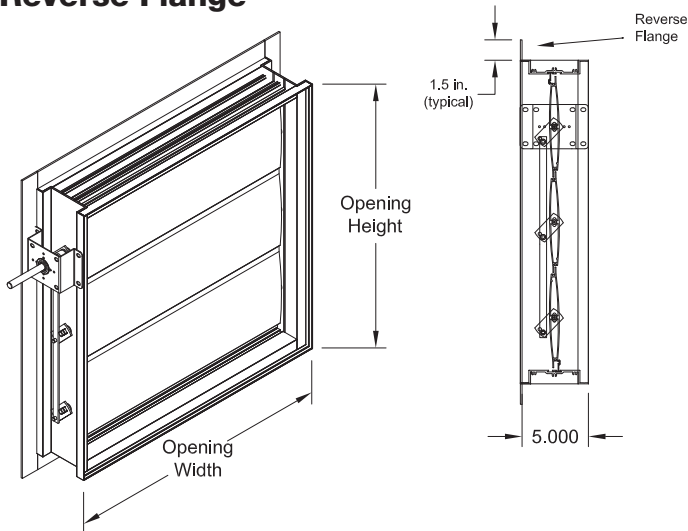

* Width and height is based on outside dimension. W & H dimensions furnished approximately 1/4 in. (6mm) undersize.

Quick Connect

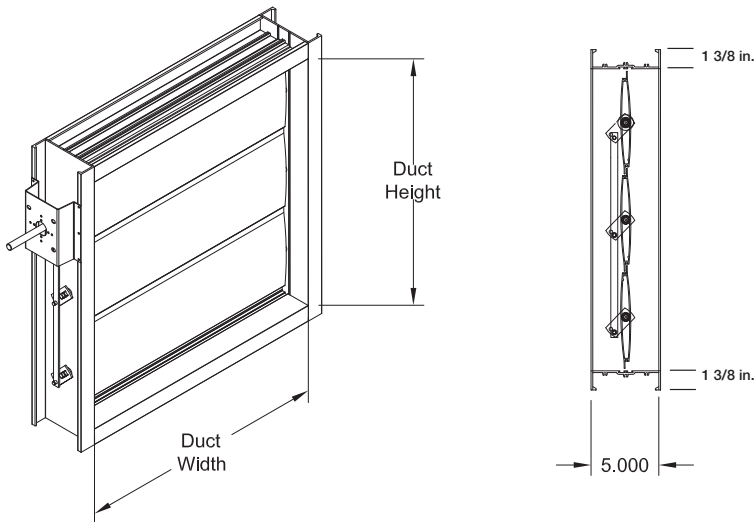

Note: When ordering the Quick Connect Frame, size is based on duct size (or inside dimension of the damper frame). Quick connect frame is actual size.

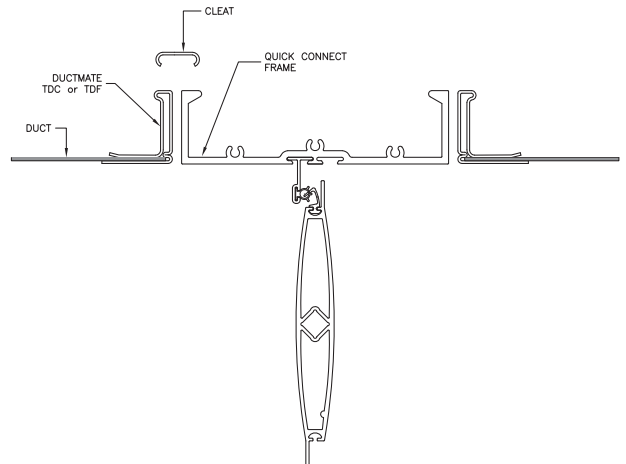

This pressure drop testing was conducted in accordance with AMCA Standard 500-D using the three configurations shown. All data has been corrected to represent standard air at a density of .075 lb/ft³ (1.2 kg/m³).

Actual pressure drop found in any HVAC system is a combination of many factors. This pressure drop information along with an analysis of other system influences should be used to estimate actual pressure losses for a damper installed in a given HVAC system.

AMCA Test Figures

Figure 5.2 Illustrates a ducted damper exhausting air into an open area. This configuration has a lower pressure drop than Figure 5.5 because entrance losses are minimized by a straight duct run upstream of the damper.

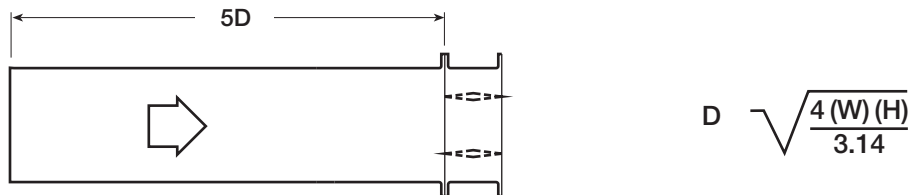

Figure 5.3 Illustrates a fully ducted damper. This configuration has the lowest pressure drop of the three test configurations because entrance and exit losses are minimized by straight duct runs upstream and downstream of the damper.

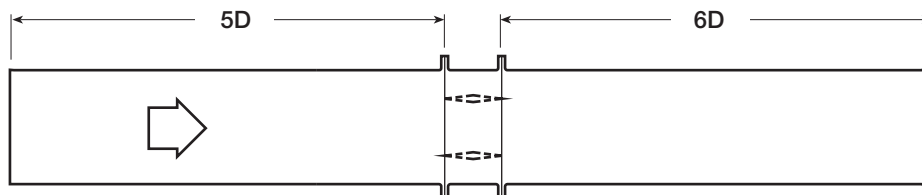
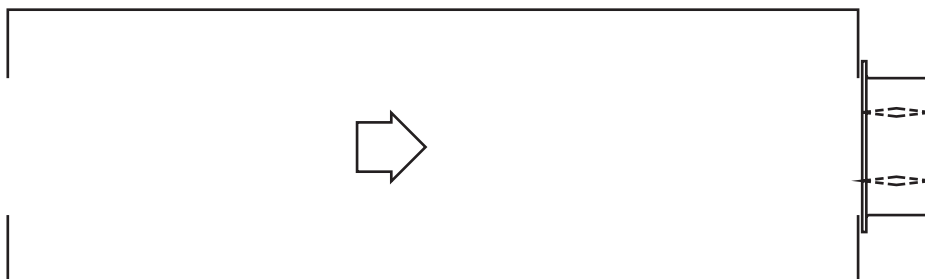
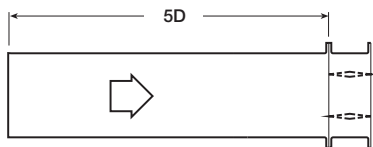

Figure 5.5 Illustrates a plenum mounted damper. This configuration has the highest pressure drop because of extremely high entrance and exit losses due to the sudden changes of area in the system.



AMCA 5.2



12 in. x 12 in. (305mm x 305mm)

Velocity (fpm)	Pressure Drop (in. wg)
500	0.01
1000	0.06
1500	0.13
2000	0.23
2500	0.35
3000	0.50
3500	0.68
4000	0.88

24 in. x 24 in. (610mm x 610mm)

Velocity (fpm)	Pressure Drop (in. wg)
500	0.01
1000	0.04
1500	0.10
2000	0.18
2500	0.28
3000	0.40
3500	0.54
4000	0.70

36 in. x 36 in. (914mm x 914mm)

Velocity (fpm)	Pressure Drop (in. wg)
500	0.01
1000	0.03
1500	0.06
2000	0.12
2500	0.18
3000	0.26
3500	0.35
4000	0.46

12 in. x 48 in. (305mm x 1219mm)

Velocity (fpm)	Pressure Drop (in. wg)
500	0.01
1000	0.06
1500	0.13
2000	0.23
2500	0.36
3000	0.51
3500	0.71
4000	0.93

48 in. x 12 in. (1219mm x 305mm)

Velocity (fpm)	Pressure Drop (in. wg)
500	0.01
1000	0.03
1500	0.06
2000	0.10
2500	0.16
3000	0.23
3500	0.30
4000	0.39

AMCA 5.3

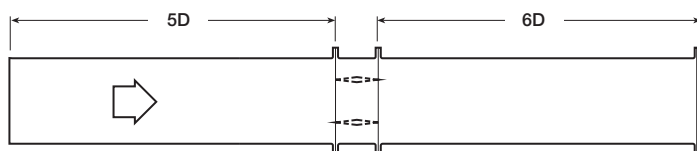

12 in. x 12 in. (305mm x 305mm)

Velocity (fpm)	Pressure Drop (in. wg)
500	0.01
1000	0.03
1500	0.07
2000	0.14
2500	0.21
3000	0.29
3500	0.39
4000	0.51

24 in. x 24 in. (610mm x 610mm)

Velocity (fpm)	Pressure Drop (in. wg)
500	0.01
1000	0.02
1500	0.04
2000	0.08
2500	0.13
3000	0.19
3500	0.26
4000	0.34

36 in. x 36 in. (914mm x 914mm)

Velocity (fpm)	Pressure Drop (in. wg)
500	0.01
1000	0.01
1500	0.02
2000	0.04
2500	0.06
3000	0.09
3500	0.13
4000	0.17

12 in. x 48 in. (305mm x 1219mm)

Velocity (fpm)	Pressure Drop (in. wg)
500	0.01
1000	0.03
1500	0.06
2000	0.11
2500	0.17
3000	0.25
3500	0.34
4000	0.45

48 in. x 12 in. (1219mm x 305mm)

Velocity (fpm)	Pressure Drop (in. wg)
500	0.01
1000	0.02
1500	0.04
2000	0.08
2500	0.12
3000	0.18
3500	0.24
4000	0.31

AMCA 5.5

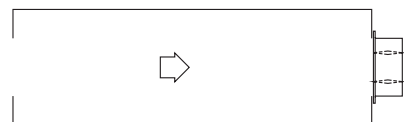

12 in. x 12 in. (305mm x 305mm)

Velocity (fpm)	Pressure Drop (in. wg)
500	0.04
1000	0.14
1500	0.31
2000	0.55
2500	0.86
3000	1.23
3500	1.67
4000	2.19

24 in. x 24 in. (610mm x 610mm)

Velocity (fpm)	Pressure Drop (in. wg)
500	0.03
1000	0.12
1500	0.27
2000	0.48
2500	0.75
3000	1.07
3500	1.47
4000	1.91

36 in. x 36 in. (914mm x 914mm)

Velocity (fpm)	Pressure Drop (in. wg)
500	0.03
1000	0.10
1500	0.22
2000	0.39
2500	0.61
3000	0.87
3500	1.19
4000	1.56

12 in. x 48 in. (305mm x 1219mm)

Velocity (fpm)	Pressure Drop (in. wg)
500	0.03
1000	0.11
1500	0.25
2000	0.46
2500	0.72
3000	1.05
3500	1.43
4000	1.87

48 in. x 12 in. (1219mm x 305mm)

Velocity (fpm)	Pressure Drop (in. wg)
500	0.03
1000	0.11
1500	0.26
2000	0.46
2500	0.72
3000	1.02
3500	1.40
4000	1.83

Leakage

Selection Criteria

Air leakage is based on operation between 32°F (0°C) and 120°F (49°C).

Tested for leakage in accordance with ANSI/AMCA Standard 500-D, Figure 5.5.

Tested for air performance in accordance with ANSI/AMCA Standard 500-D, Figures 5.2, 5.3 and 5.5.

Torque

Data are based on a torque of 5.0 in.lb./ft² (0.56 N·m) applied to close and seat the damper during the test.

VCD-43	Leakage Class*		
Maximum Damper Width	1 in. wg (0.25 kPa)	4 in. wg (1 kPa)	8 in. wg (2 kPa)
60 in. (1524mm)	1A	1	1
* applies to opposed blades only			

*Leakage Class Definitions

The *maximum* allowable leakage is defined as the following:

- Leakage Class 1A - 3 cfm/ft² at 1 in. wg (class 1A is only defined at 1 in. wg).
- Leakage Class 1
 - 4 cfm/ft² at 1 in. wg
 - 8 cfm/ft² at 4 in. wg
 - 11 cfm/ft² at 8 in. wg
 - 12.6 cfm/ft² at 10 in. wg

Velocity and Temperature Limitations

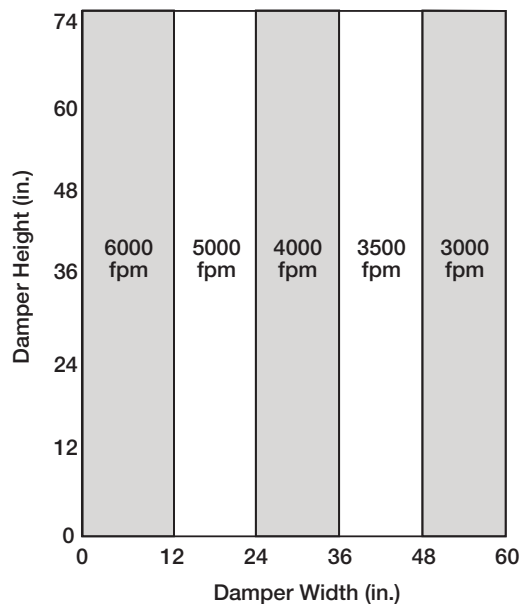

Temperature Limitations

Blade Seal	Temperature Range
TPE	-10°F to 180°F (-23°C to 82°C)
Silicone	-40°F to 250°F (-40°C to 121°C)

On dampers less than 18 in. (457mm) high, actuators may also require clearances above and/or below the damper frame. “B” and “T” dimensions are worst case clearance requirements for some dampers less than 18 in. (457mm) high. All damper sizes under 18 in. (457mm) high do not require these worst case clearances. If space availability above or below the damper is limited, each damper size should be individually evaluated.

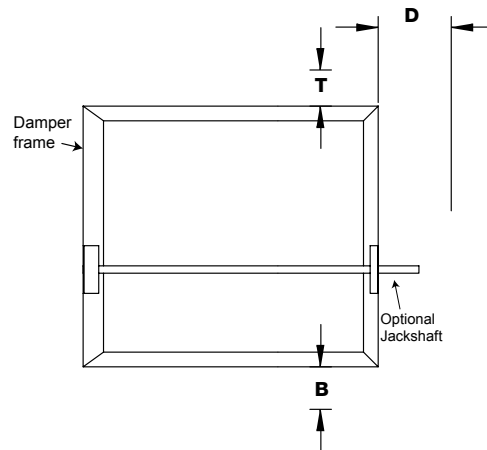

Actuator Type/Model	Height	T	B	D
	Inches (mm)	Inches (mm)		
AFBUP (-S) and FSNF Series, Belimo MSxx20 Series, Honeywell	≥6 to <10	0	12¾	6
	≥10 to <18	0	2	6
	≥18	0	0	10
FSLF, LF and TFB Series, Belimo	≥6 to <10	0	3½	6
	≥10	0	0	6
MSxx04 & MSxx09 Series, Honeywell	≥6 to <9	0	4¾	6
	≥9	0	0	6
MS75xx Series, Honeywell	≥6 to <10	0	12¾	6
	≥10 to <18	0	7	6
	≥18	0	0	6

This drawing depicts the worst case clearance requirements for an actuator with a jackshaft.

Internal mount only Actuator model	A	B	C
All except - EFB & EFCX Series	7¾ in. (197 mm)	3¾ in. (95 mm)	5⅝ in. (136.5 mm)
EFB & EFCX Series	8½ in. (216 mm)	6 in. (152mm)	8½ in. (216 mm)

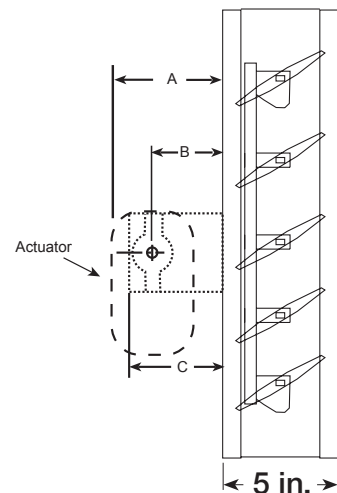

Mounting

- External - includes extension pin (standoff bracket optional)
- External kit - actuator and all mounting hardware
- Internal - blade lever

Multi-Section Assembly

Dampers larger than the maximum single section size, will be made up of a multiple of equal size sections. Multiple section dampers can be jackshafted together so that all sections operate together as shown below.

NOTE: Dampers larger than 60 in. x 74 in. (1524mm x 1880mm) are not intended to be structurally self supporting. Additional horizontal bracing is recommended to support the weight of the damper and vertical bracing should be installed as required to hold against system pressure.

Refer to IOM document 483509 for structural support requirements on multi-section assemblies.

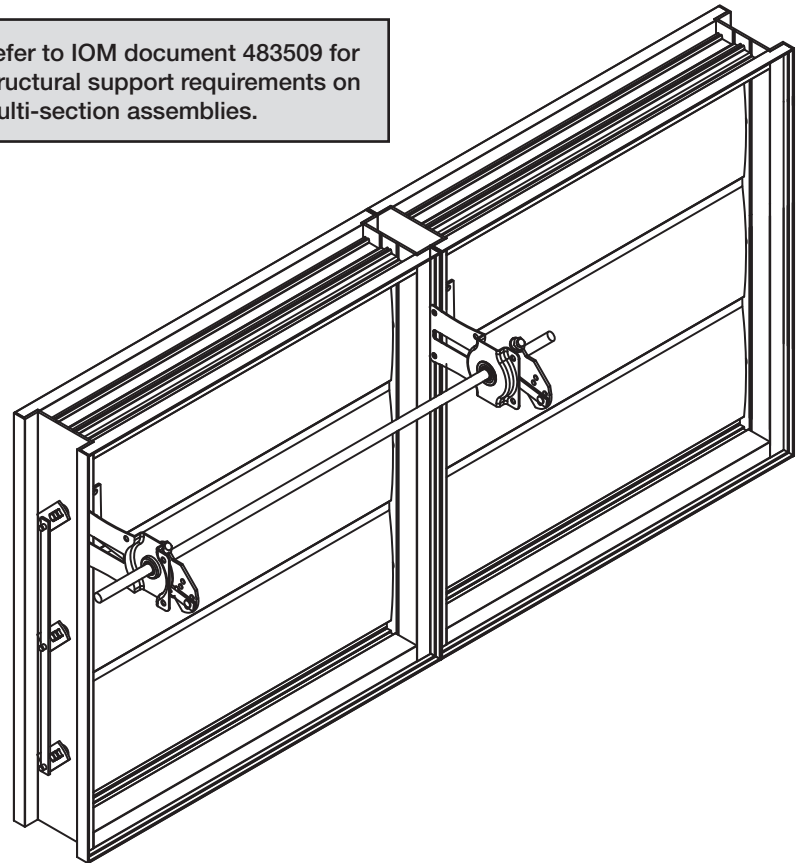

Specifications

Control dampers meeting the following specifications shall be furnished and installed where shown on plans and/or as described in schedules.

Dampers shall consist of: heavy gauge aluminum frame (0.125 in. [3.2mm] thick) with 5 in. (127mm) depth formed into a structural hat channel shape; airfoil shaped, extruded aluminum blades (0.063 in. [1.6mm] thick) with metal blade to blade overlap (seal to seal only contact is not acceptable); blades shall be symmetrical relative to their axle pivot point, presenting identical resistance to airflow and operation in either direction through the damper (blades that are non-symmetrical relative to their axle pivot point or utilize blade stops larger than 1/2 in. (13mm) are unacceptable); 1/2 in. (13mm) dia. plated steel axles turning in synthetic (acetal) sleeve bearings; TPE blade seals; flexible stainless steel jamb seals; and external (out of the airstream) blade-to-blade linkage.

Damper manufacturer's printed application and performance data including pressure, velocity and temperature limitations shall be submitted for approval showing damper suitable for pressures to 8 in. wg (2 kPa), velocities to 6000 fpm (30.5m/s) and temperatures to 250°F (121°C).

Damper manufacturer's printed performance data showing standard air leakage less than 6 cfm/ft² at 4 in. (.003 m³/s at 1 kPa) wg in either direction through the damper shall be submitted for approval.

Testing and ratings shall be developed in accordance with the latest edition of AMCA Standard 500-D.

Basis of design is VCD-43.