



# Model FSD-312

## Combination Fire Smoke Dampers Steel Airfoil Blades

### UL 555S Leakage Class II UL 555 1½ Hour Fire Resistance Rating



### Application

Model FSD-312 is a high performance combination fire smoke damper with Class II leakage. High strength airfoil blades ensure the lowest resistance to airflow in HVAC systems with velocities to 4000 fpm (20.3 m/s) and pressures to 8 in. wg (2 kPa). Model FSD-312 may be installed vertically (with blades running horizontal) or horizontally and is rated for airflow and leakage in either direction.

### Ratings

#### UL 555 Fire Resistance Rating

**Fire Rating:** 1½ hours

**Dynamic Closure Rating:** Actual ratings are size dependent

**Velocity:** Up to 4,000 fpm (20.3 m/s)

**Pressure:** Up to 8 in. wg (2 kPa)

#### UL 555S Leakage Rating

**Leakage Class:** II

**Operational Rating:** Actual ratings are size dependent

**Velocity:** Up to 4,000 fpm (20.3 m/s)

**Pressure:** Up to 8 in. wg (2 kPa)

**Temperature:** Up to 350°F (177°C) - depending upon the actuator

Width and Height dimensions furnished approximately ¼ in. (6mm) undersize. Add sleeve thickness for overall sleeved damper dimension.

Right hand drive is shown. Left hand drive is available upon request.

Construction	Standard	Optional
Frame Material	Galvanized steel	-
Frame Material Thickness	16 ga. (1.5mm)	-
Frame Type	5 in. x 1 in. (127mm x 25mm) hat channel	-
Blade Material	Galvanized steel	-
Blade Material Thickness	14 ga. (2mm) equivalent	-
Blade Type	Airfoil	-
Linkage	Plated steel out of airstream, concealed in jamb	316SS
Axle Bearings	316SS	-
Axle Material	Plated steel	316SS
Blade Seals	Silicone	-
Jamb Seals	Stainless Steel	-
Closure Device	RRL	RRL/OCI, TOR, Fusible Link
Closure Temperature	165°F (74°C)	212°F (100°C), 250°F (121°C), 286°F (141°C), 350°F (177°C)

Model FSD-312 meets the requirements for fire dampers, smoke dampers and combination fire smoke dampers established by:

#### National Fire Protection Association

NFPA Standards 80, 90A, 92, 101 & 105

#### IBC International Building Codes



See complete marking on product.

UL 555 and UL 555S  
Classification R16690

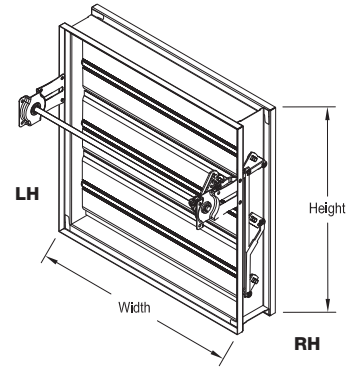
W x H	Minimum Size	Maximum Size*		
		Single Section	Multiple Section	
			Horizontal	Vertical
Inches	8 x 6	32 x 50	144 x 96	128 x 100
mm	203 x 152	813 x 1270	3658 x 2438	3251 x 2540

\*Note: Maximum sizes are dependent on velocities and pressure.

### Features:

- Frames are constructed with reinforced corners. Low profile head and sill are used on sizes less than 17 in. high (432mm).
- Blades are a double skin airfoil with full length structural reinforcement.

- Factory mounted accessories
  - Quick connect breakaway connections
  - Access doors
- Greenheck test switches (GTS-1, -2, -3, -4)
- Momentary test switch
- POC retaining angles
- RRL/OCI (Open closed indication switches)
- TOR (Temperature limited override)
- Sealed transitions and sleeves
- Security bars
- Smoke detectors
- Transitions: R, C, O



## Pressure Drop Data

This pressure drop testing was conducted in accordance with AMCA Standard 500-D using the three configurations shown. All data has been corrected to represent standard air at a density of .075 lb/ft<sup>3</sup>(1.201 kg/m<sup>3</sup>).

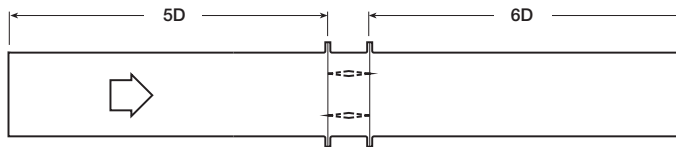
Actual pressure drop found in any HVAC system is a combination of many factors. This pressure drop information along with an analysis of other system influences should be used to estimate actual pressure losses for a damper installed in a given HVAC system.

### AMCA Test Figures

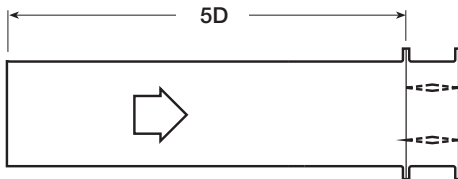
**Figure 5.3** Illustrates a fully ducted damper. This configuration has the lowest pressure drop of the three test configurations because entrance and exit losses are minimized by straight duct runs upstream and downstream of the damper.

**Figure 5.2** Illustrates a ducted damper exhausting air into an open area. This configuration has a lower pressure drop than Figure 5.5 because entrance losses are minimized by a straight duct run upstream of the damper.

**Figure 5.5** Illustrates a plenum mounted damper. This configuration has the highest pressure drop because of extremely high entrance and exit losses due to the sudden changes of area in the system.

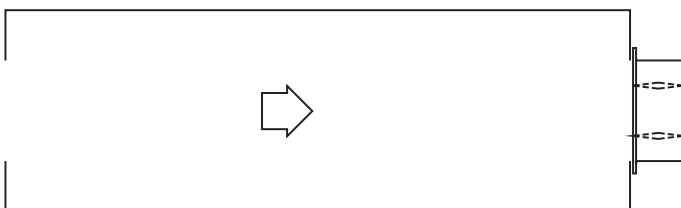


**Figure 5.3**



$$D = \sqrt{\frac{4(W)(H)}{3.14}}$$

**Figure 5.2**

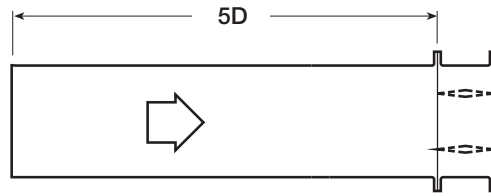


**Figure 5.5**

# Pressure Drop

# FSD-312

AMCA Figure 5.2



12 in. x 12 in. (305mm x 305mm)

Velocity (fpm)	Pressure Drop (in. wg)
500	0.03
1000	0.11
1500	0.24
2000	0.42
2500	0.66
3000	0.95
3500	1.30
4000	1.70

24 in. x 24 in. (610mm x 610mm)

Velocity (fpm)	Pressure Drop (in. wg)
500	0.01
1000	0.06
1500	0.12
2000	0.22
2500	0.34
3000	0.49
3500	0.67
4000	0.87

36 in. x 36 in. (914mm x 914mm)

Velocity (fpm)	Pressure Drop (in. wg)
500	0.01
1000	0.05
1500	0.12
2000	0.21
2500	0.32
3000	0.47
3500	0.63
4000	0.83

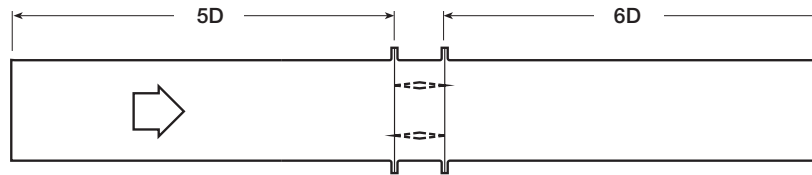
12 in. X 48 in. (305mm x 1219mm)

Velocity (fpm)	Pressure Drop (in. wg)
500	0.01
1000	0.05
1500	0.12
2000	0.21
2500	0.33
3000	0.48
3500	0.65
4000	0.85

48 in. x 12 in. (1219mm x 305mm)

Velocity (fpm)	Pressure Drop (in. wg)
500	0.02
1000	0.08
1500	0.18
2000	0.33
2500	0.51
3000	0.74
3500	1.00
4000	1.31

AMCA Figure 5.3



12 in. x 12 in. (305mm x 305mm)

Velocity (fpm)	Pressure Drop (in. wg)
500	0.01
1000	0.06
1500	0.13
2000	0.23
2500	0.37
3000	0.53
3500	0.73
4000	0.95

24 in. x 24 in. (610mm x 610mm)

Velocity (fpm)	Pressure Drop (in. wg)
500	0.01
1000	0.02
1500	0.06
2000	0.10
2500	0.16
3000	0.23
3500	0.32
4000	0.42

36 in. x 36 in. (914mm x 914mm)

Velocity (fpm)	Pressure Drop (in. wg)
500	0.01
1000	0.02
1500	0.05
2000	0.09
2500	0.14
3000	0.21
3500	0.29
4000	0.38

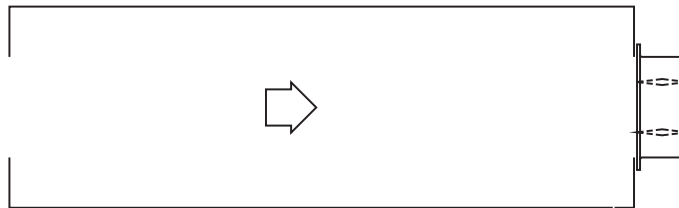
12 in. X 48 in. (305mm x 1219mm)

Velocity (fpm)	Pressure Drop (in. wg)
500	0.01
1000	0.03
1500	0.06
2000	0.11
2500	0.18
3000	0.25
3500	0.34
4000	0.45

48 in. x 12 in. (1219mm x 305mm)

Velocity (fpm)	Pressure Drop (in. wg)
500	0.01
1000	0.04
1500	0.10
2000	0.18
2500	0.29
3000	0.42
3500	0.57
4000	0.74

AMCA Figure 5.5



12 in. x 12 in. (305mm x 305mm)

Velocity (fpm)	Pressure Drop (in. wg)
500	0.04
1000	0.18
1500	0.42
2000	0.75
2500	1.17
3000	1.68
3500	2.29
4000	2.09

24 in. x 24 in. (610mm x 610mm)

Velocity (fpm)	Pressure Drop (in. wg)
500	0.03
1000	0.13
1500	0.29
2000	0.52
2500	0.81
3000	1.17
3500	1.60
4000	2.14

36 in. x 36 in. (914mm x 914mm)

Velocity (fpm)	Pressure Drop (in. wg)
500	0.03
1000	0.12
1500	0.27
2000	0.48
2500	0.75
3000	1.08
3500	1.48
4000	1.93

12 in. X 48 in. (305mm x 1219mm)

Velocity (fpm)	Pressure Drop (in. wg)
500	0.03
1000	0.12
1500	0.27
2000	0.49
2500	0.77
3000	1.11
3500	1.51
4000	1.97

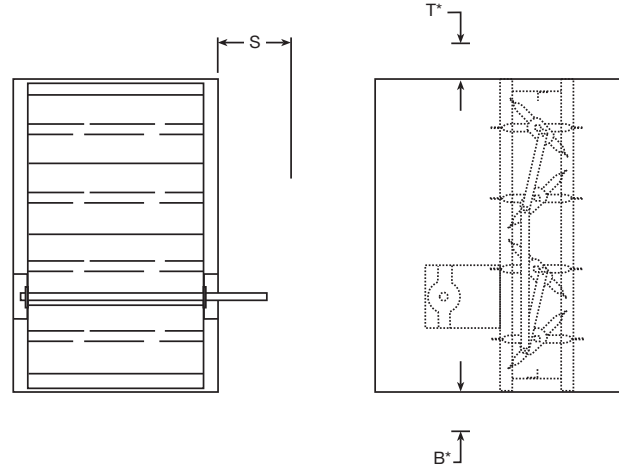
48 in. x 12 in. (1219mm x 305mm)

Velocity (fpm)	Pressure Drop (in. wg)
500	0.03
1000	0.14
1500	0.32
2000	0.57
2500	0.89
3000	1.28
3500	1.75
4000	2.29

## Actuators and Accessories Space Envelopes

Externally mounted actuators always require space outside of the damper sleeve. The “S” dimension illustrates the clearance required for various available actuators.

On dampers less than 18 in. (457mm) high, actuators may also require clearances above and/or below the sleeve. “B” and “T” dimensions are **worst** case clearance requirements for some dampers less than 18 in. (457 mm) high. All dampers 18 in. (457mm) or more in height, do not require these worst case clearances. If space availability above or below the damper sleeve is limited, each damper size should be individually evaluated.



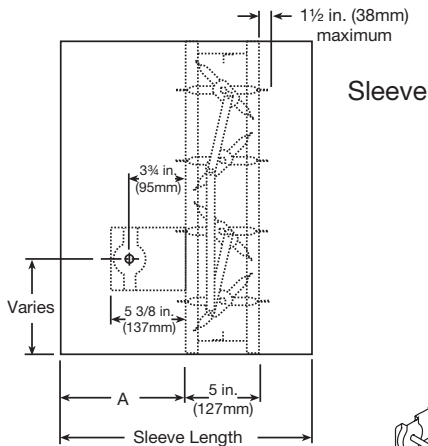
Actuator Type/Model	B*	T*	S	
	With RRL, RRL/OCI, or TOR	With RRL, RRL/OCI, or TOR	No	Yes
<b>120 Volt AC</b>				
FSLF120 (-S) Belimo	7 <sup>1</sup> / <sub>16</sub> in. (195mm)	0	6 in. (152mm)	NA
FSNF120 (-S) Belimo	½ in. (13mm)	9 <sup>1</sup> / <sub>16</sub> in. (249mm)	6 in. (152mm)	9 in. (229mm)
FSTF120 (-S) Belimo	7 <sup>1</sup> / <sub>16</sub> in. (195mm)	0	6 in. (152mm)	NA
MS4104 Series Honeywell	½ in. (13mm)	8½ in. (216mm)	6 in. (152mm)	NA
MS4X09 Series Honeywell	½ in. (13mm)	8½ in. (216mm)	6 in. (152mm)	NA
MS4120 Series Honeywell	½ in. (13mm)	9 <sup>1</sup> / <sub>16</sub> in. (249mm)	6 in. (152mm)	9 in. (229mm)
<b>24 Volt AC</b>				
FSAF24 (-S) Belimo	½ in. (13mm)	9 <sup>1</sup> / <sub>16</sub> in. (249mm)	6 in. (152mm)	NA
FSTF24 (-S) Belimo	7 <sup>1</sup> / <sub>16</sub> in. (195mm)	½ in. (13mm)	6 in. (152mm)	NA
FSLF24-S Belimo	7 <sup>1</sup> / <sub>16</sub> in. (195mm)	0	6 in. (152mm)	NA
FSNF24 (-S) Belimo	½ in. (13mm)	9 <sup>1</sup> / <sub>16</sub> in. (249mm)	6 in. (152mm)	9 in. (229mm)
MS8104 Series Honeywell	½ in. (13mm)	8½ in. (216mm)	6 in. (152mm)	NA
MS8120 Series Honeywell	½ in. (13mm)	9 <sup>1</sup> / <sub>16</sub> in. (249mm)	6 in. (152mm)	9 in. (229mm)
<b>230 Volt AC</b>				
FSLF230-S Belimo	7 <sup>1</sup> / <sub>16</sub> in. (195mm)	0	6 in. (152mm)	NA
FSNF230-S Belimo	½ in. (13mm)	9 <sup>1</sup> / <sub>16</sub> in. (249mm)	6 in. (152mm)	9 in. (229mm)
FSTF230-S Belimo	7 <sup>1</sup> / <sub>16</sub> in. (195mm)	½ in. (13mm)	6 in. (152mm)	NA
MS4604 Series Honeywell	½ in. (13mm)	8½ in. (216mm)	6 in. (152mm)	NA
MS4X09 Series Honeywell	½ in. (13mm)	8½ in. (216mm)	6 in. (152mm)	NA
MS4620 Series Honeywell	½ in. (13mm)	9 <sup>1</sup> / <sub>16</sub> in. (249mm)	6 in. (152mm)	9 in. (229mm)

\* For dampers 18 in. (457mm) or more in height these dimensions are 0 in.

## Damper Sleeve Dimensional Data

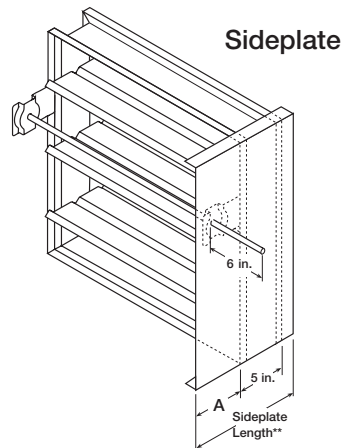
The drawings below and corresponding table show the position of the FSD-312 damper when mounted in a factory sleeve. The standard mounting locations provide enough space for the mounting of actuators, controls and allow space for installation of retaining angles and duct connections.

The standard location of a damper mounted in a factory sleeve ("A" dimension) is shown below. The damper can be positioned at other locations within a range of 6 in. (152mm) to 16 in. (406mm) for the "A" dimension.



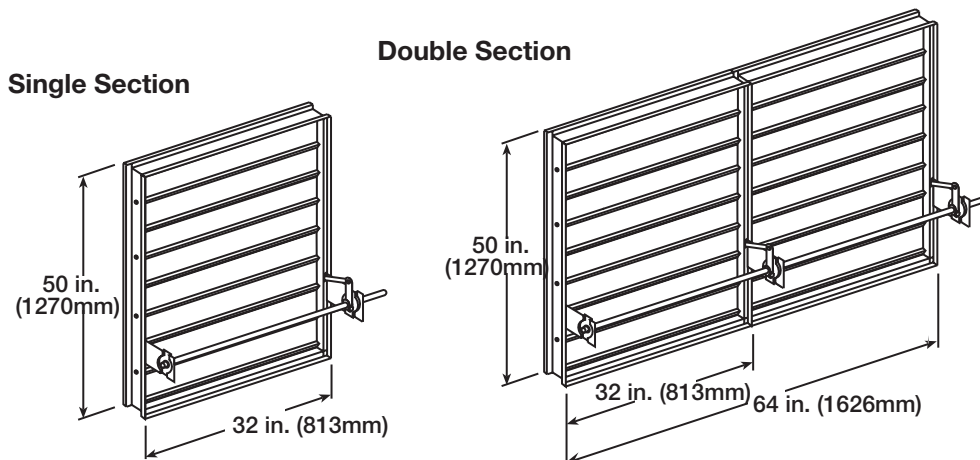
in. (mm)	"A" Dimension		
	Sleeve Std	Sleeve Max	Sideplate
All Dampers (RRL)	7 3/16 in. (183)	16 (406)	6 3/16 (157)
When Height is 11 in. (279) or less with RRL, RRL/OCI, or TOR	12 (305)	16 (406)	12 (305)

**NOTE:** Entire damper frame is not required to be installed within the wall. The damper blades, when closed should be contained within the wall.

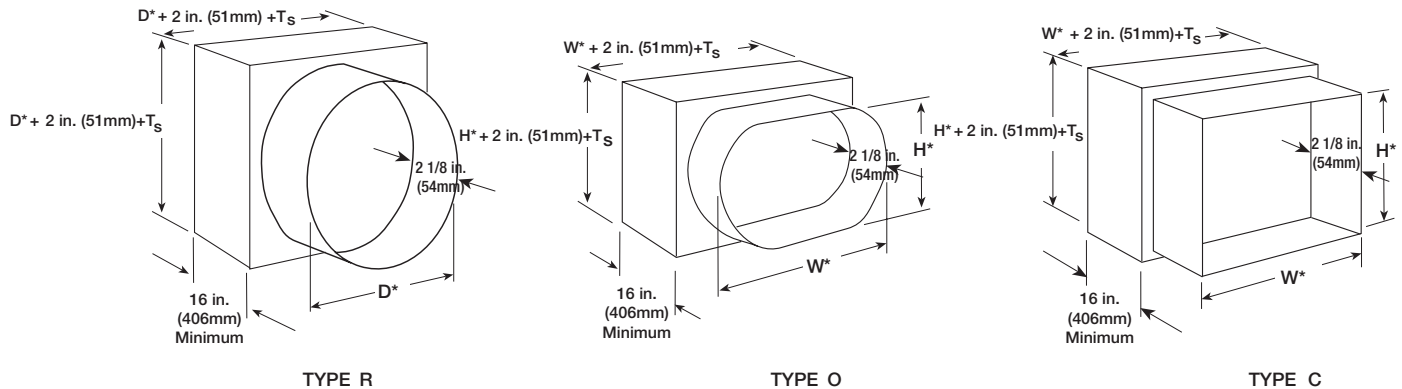


## Damper Sizing Information

Dampers larger than maximum single section size are supplied as a factory assembly of two or more sections of equal size. The following figures show maximum damper section size and assembly configurations for multi-section dampers.



When a combination fire smoke damper is being used in conjunction with round or oval ductwork, the FSD-312 can be supplied in a factory sleeve with round or oval transitions on both ends of the sleeve. Dampers should be ordered to the duct dimensions. Drawings below show overall damper size.



\*These dimensions are furnished approximately 1/4 in. (6mm) undersize, except round and oval dimensions which are approximately 1/8 in. (3mm) undersize.

Ts = (2)(Sleeve Thickness)

## Specifications

Combination Fire Smoke Dampers meeting the following specifications shall be furnished and installed where shown on plans and/or as described in schedules. Dampers shall meet the requirements of NFPA 80, 90A, 92, 101, and 105 and further shall be tested, rated and labeled in accordance with the latest edition of UL Standards 555 and 555S. Dampers shall have a UL555 fire rating of 1½ hours and be of low leakage design qualified to UL 555S Leakage Class II.

Each damper/actuator combination shall have a UL 555S elevated temperature rating of 250° F (121°C) minimum and shall be operational and dynamic rated to operate at maximum design air flow at its installed location. Each damper shall be supplied with an appropriate actuator installed by the damper manufacturer at the time of damper fabrication. Damper actuator shall be (specifier select one of the following) electric type for 120, 24, or 230 volt operation.

Damper blades shall be of the double skin airfoil type and shall have an equivalent thickness of 14 ga. (2mm).

Damper frame shall be galvanized steel formed into a structural hat channel shape with reinforced corners. Bearings shall be 316SS sleeve type rotating in extruded holes in the damper frame. Blade edge seals shall be silicone rubber designed to inflate and provide a tighter seal against leakage as pressure on either side of the damper increases. Jamb seals shall be stainless steel compression type. Blades shall be symmetrical relative to their axle pivot point, presenting identical resistance to airflow in either direction or pressure on either side of the damper.

Damper must be rated for mounting vertically (with blades running horizontal) or horizontally and be UL 555S rated for leakage and airflow in either direction through the damper. Each damper shall be supplied with a 165°F (74°C) RRL. Testing and ratings to be in accordance with AMCA standard 500-D.

The basis of design is Model FSD-312.