



# Model DFD-210

**Multi-blade Fire Damper  
Steel 3V Blades**

**UL 555 1½ Hour Fire Resistance Rating**

## Application

Model DFD-210 is a dynamic rated multi-blade fire damper with 3V style blades. The DFD-210 is qualified to 4,000 fpm (20.3 m/s) and 10 in. wg (2.5 KPa) for dynamic closure in emergency fire situations. The DFD-210 may be installed vertically (with blades running horizontal) or horizontally and is rated for airflow in either direction.

## Ratings

### UL 555 Fire Resistance Rating

**Fire Rating:** 1½ hours

**Dynamic Closure Rating:** Actual limits are size dependent

**Maximum Velocity:** 4,000 fpm (20.3 m/s) up to 32 in. x 50 in. (813mm x 1270mm)  
2,000 fpm (10.2 m/s) sizes greater than that.

**Maximum Pressure:** 10 in. wg (2.5 kPa)

| Construction             | Standard   | Optional  |
|--------------------------|--|---|
| Frame Material           | Galvanized steel                                 | -   |
| Frame Material Thickness | 16 ga. (1.5mm)                                   | -   |
| Frame Type               | 5 in. x 1 in. (127mm x 25mm) hat channel         | -   |
| Blade Material           | Galvanized steel                                 | -   |
| Blade Material Thickness | 16 ga. (1.5mm)                                   | -   |
| Blade Type               | 3V   | -   |
| Linkage                  | Plated steel out of airstream, concealed in jamb |   |
| Axle Bearings            | 316SS  | -   |
| Axle Material            | Plated steel                                     | -   |
| Jamb Seals               | Stainless Steel                                  | -   |
| Closure Device           | Fusible link                                     | -   |
| Closure Temperature      | 165°F (74°C)                                     | 212°F (100°C),<br>286°F (141°C),<br>350°F (177°C) |
| Actuator                 | Manual quadrant                                  | -   |

| W x H  | Minimum Size | Maximum Size               |                                    |
|--------|--------------|----------------------------|------------------------------------|
|        |              | Single Section             | Multi-Section                      |
| Inches | 8 x 6        | 36 x 36 or<br>32 x 50      | 128 x 96 (H)<br>128 x 100 (V)      |
| mm     | 203 x 152    | 914 x 914 or<br>813 x 1270 | 3251 x 2438 (H)<br>3251 x 2540 (V) |

H = Horizontal V = Vertical

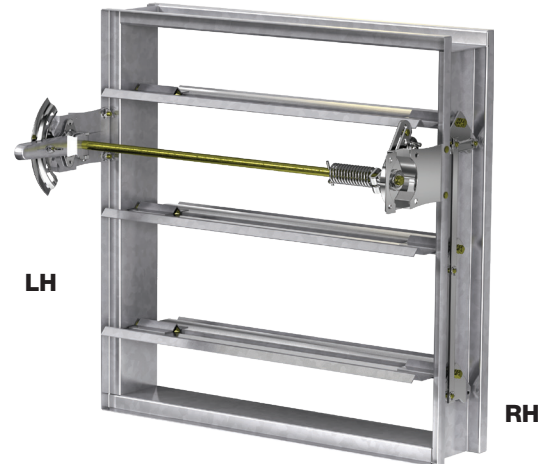

W & H dimensions furnished approximately ¼ in. (6mm) undersize. Add sleeve thickness for overall sleeved damper dimension.

Model DFD-210 meets the requirements for fire dampers established by:

**National Fire Protection Association**  
NFPA Standards 80, 90A, & 101  
**IBC International Building Codes**



See complete marking on product.  
UL 555 Classification  
R16690

## Features and Options

- Frames are constructed with reinforced corners. Low profile head and sill are used on sizes less than 17 in. (432mm) high.
- Blades are reinforced with 3 longitudinal structurally designed vee's.
- Factory installed accessories
  - Quick connect breakaway connections
  - Access doors
- Grille tabs
- OCI (Open Closed Indication Switches)\*
- POC retaining angles
- Security bars
- Sealed Transition and sleeves
- Sleeves
- Test Switch (GTS-4)
- Transition (R, C, O)

\*Note: Dampers more than one section wide will be furnished with a single OCI device per row when selected.

This pressure drop testing was conducted in accordance with AMCA Standard 500-D using the three configurations shown. All data has been corrected to represent standard air at a density of .075 lb/ft<sup>3</sup> (1.201 kg/m<sup>3</sup>).

Actual pressure drop found in any HVAC system is a combination of many factors. This pressure drop information along with an analysis of other system influences should be used to estimate actual pressure losses for a damper installed in a given HVAC system.

## AMCA Test Figures

**Figure 5.3** Illustrates a fully ducted damper. This configuration has the lowest pressure drop of the three test configurations because entrance and exit losses are minimized by straight duct runs upstream and downstream of the damper.

**Figure 5.2** Illustrates a ducted damper exhausting air into an open area. This configuration has a lower pressure drop than Figure 5.5 because entrance losses are minimized by a straight duct run upstream of the damper.

**Figure 5.5** Illustrates a plenum mounted damper. This configuration has the highest pressure drop because of extremely high entrance and exit losses due to the sudden changes of area in the system.

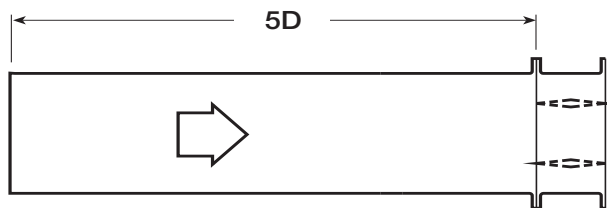
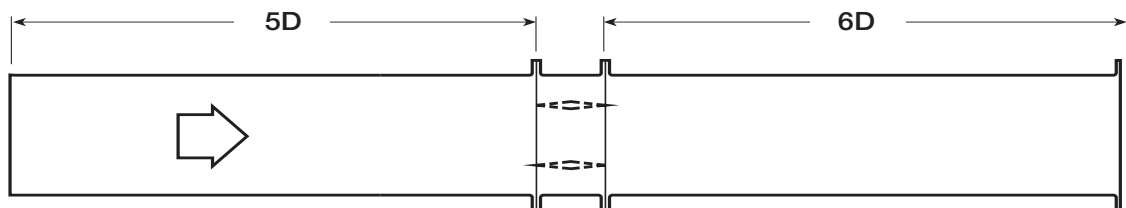

$$D = \sqrt{\frac{4(W)(H)}{3.14}}$$

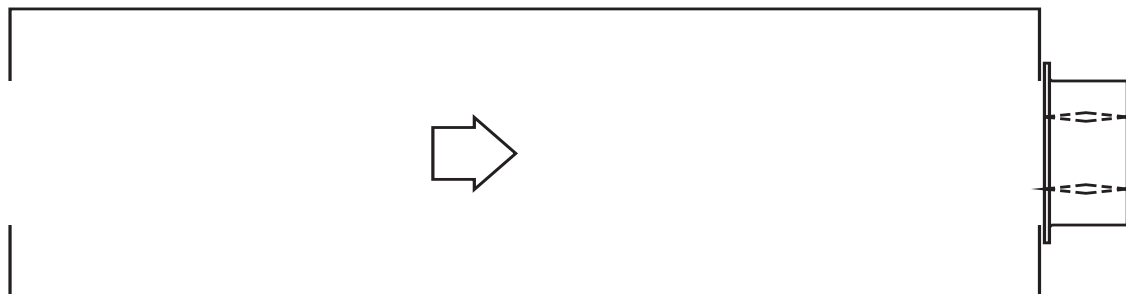

### AMCA Figure 5.2

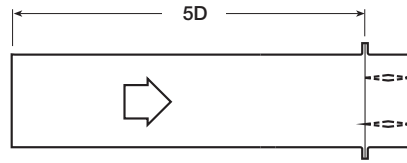

12 in. x 12 in. (305mm x 305mm)

| Velocity (fpm) | Pressure Drop (in. wg) |
|----------------|------------------------|
| 500            | 0.04                   |
| 1000           | 0.14                   |
| 1500           | 0.31                   |
| 2000           | 0.55                   |
| 2500           | 0.86                   |
| 3000           | 1.24                   |
| 3500           | 1.69                   |
| 4000           | 2.20                   |

24 in. x 24 in. (610mm x 610mm)

| Velocity (fpm) | Pressure Drop (in. wg) |
|----------------|------------------------|
| 500            | 0.02                   |
| 1000           | 0.07                   |
| 1500           | 0.16                   |
| 2000           | 0.29                   |
| 2500           | 0.45                   |
| 3000           | 0.65                   |
| 3500           | 0.89                   |
| 4000           | 1.16                   |

36 in. x 36 in. (914mm x 914mm)

| Velocity (fpm) | Pressure Drop (in. wg) |
|----------------|------------------------|
| 500            | 0.01                   |
| 1000           | 0.04                   |
| 1500           | 0.09                   |
| 2000           | 0.16                   |
| 2500           | 0.25                   |
| 3000           | 0.36                   |
| 3500           | 0.49                   |
| 4000           | 0.64                   |

12 in. x 48 in. (305mm x 1219mm)

| Velocity (fpm) | Pressure Drop (in. wg) |
|----------------|------------------------|
| 500            | 0.01                   |
| 1000           | 0.06                   |
| 1500           | 0.13                   |
| 2000           | 0.23                   |
| 2500           | 0.36                   |
| 3000           | 0.52                   |
| 3500           | 0.70                   |
| 4000           | 0.92                   |

48 in. x 12 in. (1219mm x 305mm)

| Velocity (fpm) | Pressure Drop (in. wg) |
|----------------|------------------------|
| 500            | 0.03                   |
| 1000           | 0.10                   |
| 1500           | 0.23                   |
| 2000           | 0.41                   |
| 2500           | 0.63                   |
| 3000           | 0.91                   |
| 3500           | 1.24                   |
| 4000           | 1.62                   |

### AMCA Figure 5.3

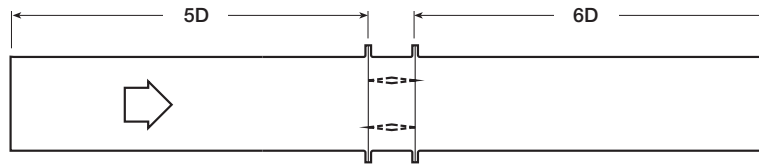

12 in. x 12 in. (305mm x 305mm)

| Velocity (fpm) | Pressure Drop (in. wg) |
|----------------|------------------------|
| 500            | 0.02                   |
| 1000           | 0.09                   |
| 1500           | 0.20                   |
| 2000           | 0.36                   |
| 2500           | 0.56                   |
| 3000           | 0.81                   |
| 3500           | 1.10                   |
| 4000           | 1.44                   |

24 in. x 24 in. (610mm x 610mm)

| Velocity (fpm) | Pressure Drop (in. wg) |
|----------------|------------------------|
| 500            | 0.01                   |
| 1000           | 0.04                   |
| 1500           | 0.09                   |
| 2000           | 0.16                   |
| 2500           | 0.25                   |
| 3000           | 0.35                   |
| 3500           | 0.48                   |
| 4000           | 0.63                   |

36 in. x 36 in. (914mm x 914mm)

| Velocity (fpm) | Pressure Drop (in. wg) |
|----------------|------------------------|
| 500            | 0.01                   |
| 1000           | 0.03                   |
| 1500           | 0.06                   |
| 2000           | 0.11                   |
| 2500           | 0.17                   |
| 3000           | 0.24                   |
| 3500           | 0.33                   |
| 4000           | 0.42                   |

12 in. x 48 in. (305mm x 1219mm)

| Velocity (fpm) | Pressure Drop (in. wg) |
|----------------|------------------------|
| 500            | 0.01                   |
| 1000           | 0.04                   |
| 1500           | 0.10                   |
| 2000           | 0.17                   |
| 2500           | 0.27                   |
| 3000           | 0.39                   |
| 3500           | 0.53                   |
| 4000           | 0.70                   |

48 in. x 12 in. (1219mm x 305mm)

| Velocity (fpm) | Pressure Drop (in. wg) |
|----------------|------------------------|
| 500            | 0.02                   |
| 1000           | 0.07                   |
| 1500           | 0.16                   |
| 2000           | 0.29                   |
| 2500           | 0.45                   |
| 3000           | 0.64                   |
| 3500           | 0.88                   |
| 4000           | 1.14                   |

### AMCA Figure 5.5

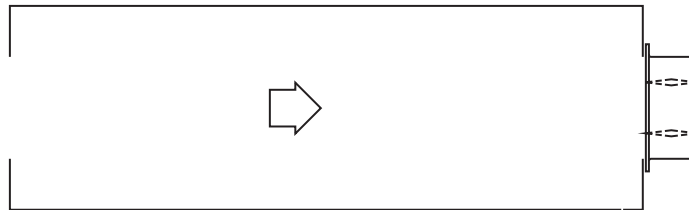

12 in. x 12 in. (305mm x 305mm)

| Velocity (fpm) | Pressure Drop (in. wg) |
|----------------|------------------------|
| 500            | 0.06                   |
| 1000           | 0.22                   |
| 1500           | 0.50                   |
| 2000           | 0.89                   |
| 2500           | 1.39                   |
| 3000           | 2.00                   |
| 3500           | 2.72                   |
| 4000           | 3.55                   |

24 in. x 24 in. (610mm x 610mm)

| Velocity (fpm) | Pressure Drop (in. wg) |
|----------------|------------------------|
| 500            | 0.03                   |
| 1000           | 0.14                   |
| 1500           | 0.31                   |
| 2000           | 0.54                   |
| 2500           | 0.85                   |
| 3000           | 1.22                   |
| 3500           | 1.66                   |
| 4000           | 2.17                   |

36 in. x 36 in. (914mm x 914mm)

| Velocity (fpm) | Pressure Drop (in. wg) |
|----------------|------------------------|
| 500            | 0.03                   |
| 1000           | 0.12                   |
| 1500           | 0.26                   |
| 2000           | 0.46                   |
| 2500           | 0.73                   |
| 3000           | 1.05                   |
| 3500           | 1.42                   |
| 4000           | 1.86                   |

12 in. x 48 in. (305mm x 1219mm)

| Velocity (fpm) | Pressure Drop (in. wg) |
|----------------|------------------------|
| 500            | 0.03                   |
| 1000           | 0.13                   |
| 1500           | 0.30                   |
| 2000           | 0.53                   |
| 2500           | 0.83                   |
| 3000           | 1.19                   |
| 3500           | 1.62                   |
| 4000           | 2.11                   |

48 in. x 12 in. (1219mm x 305mm)

| Velocity (fpm) | Pressure Drop (in. wg) |
|----------------|------------------------|
| 500            | 0.04                   |
| 1000           | 0.17                   |
| 1500           | 0.38                   |
| 2000           | 0.67                   |
| 2500           | 1.04                   |
| 3000           | 1.50                   |
| 3500           | 2.05                   |
| 4000           | 2.67                   |

# Damper Sizing Information

Dampers larger than maximum single section size are supplied as a factory assembly of two or more sections of equal size. The following figures show maximum damper section size and assembly configurations for multi-section dampers.

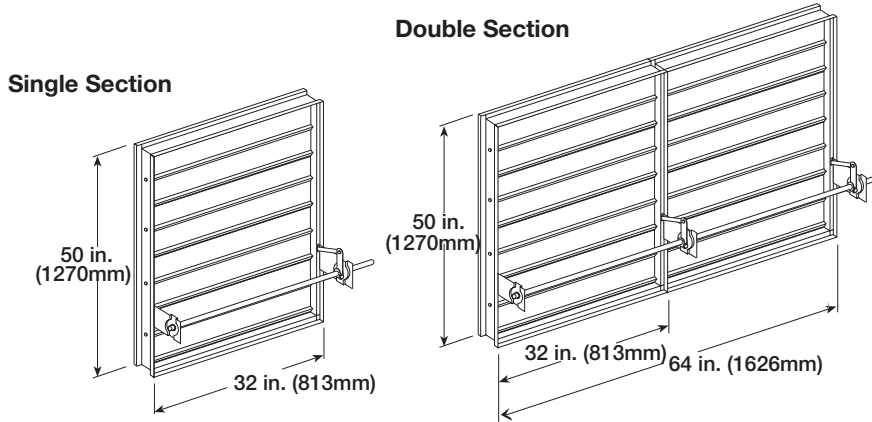

## Damper Sleeve Dimensional Data

The drawings below and corresponding table show the position of the DFD-210 damper when mounted in a factory sleeve. The standard mounting locations provide enough space for the mounting of manual quadrant, controls and allow space for installation of retaining angles and duct connections. The "A" dimension is the location of the damper mounted in a factory sleeve. The table below shows the Standard and Maximum "A" dimensions.

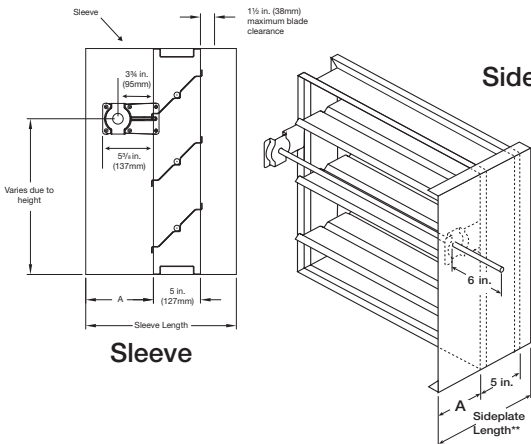

| in. (mm)                                     | "A" Dimension    |            |              |
|--|------------------|------------|--------------|
|  | Sleeve Std       | Sleeve Max | Sideplate    |
| All Dampers                                  | 7 3/16 in. (183) | 16 (406)   | 6 3/16 (157) |
| When Height is 11 in. (279) or less with OCI | 12 (305)         | 16 (406)   | 12 (305)     |

**NOTE:** Entire damper frame is not required to be installed within the wall. The damper blades, when closed should be contained within the wall.

## Specifications

Fire Dampers meeting the following specifications shall be furnished and installed where shown on plans and/or as described in schedules. Dampers shall meet the requirements of the latest edition of NFPA 80, 90A and 101.

Dampers shall be tested, rated and labeled in accordance with the latest edition of UL Standard 555. Dampers shall have a UL 555 fire rating of 1½ hours. Each damper shall be equipped with a heat responsive device which has been tested and approved for use with the damper assembly in accordance with UL 555. The heat responsive device shall have a temperature rating of (specifier select one of the following) 165°F (74°C), 212°F (100°C), 286°F (141°C), or 350°F (177°C). Dampers shall be UL labeled for use in dynamic systems. The damper shall have a dynamic closure pressure rating of 4 in. wg (1 kPa).

Damper actuator shall be manual quadrant. Manufacturer's submittal data shall indicate actuator space requirements around the damper.

The Damper Manufacturer's submittal data shall certify all air performance pressure drop data is licensed in accordance with the

AMCA Certified Ratings Program for Test Figures 5.2, 5.3 and 5.5.

Damper air performance data shall be developed in accordance with the latest edition of AMCA Standard 500-D.

Damper blades shall be 16 ga. (1.5mm) galvanized steel 3V type with three longitudinal grooves for reinforcement. Blades shall be symmetrical relative to their axle pivot point, presenting identical resistance to airflow and operation in either direction through the damper (blades that are non-symmetrical relative to their axle pivot point or utilize blade stops larger than ½ in. (13mm) are unacceptable).

Damper frame shall be 16 ga. (1.5mm) galvanized steel formed into a structural hat channel shape with reinforced corners. Bearings shall be 316 stainless steel type rotating in extruded holes in the damper frame for maximum service. Axles shall be square and positively locked into the damper blade. Jamb seals shall be stainless steel compression type. Basis of design is Model DFD-210.